



LessLess. Jean Nouvel Design

Ho disegnato Less nel 1994, in occasione dell'apertura della Fondazione Cartier a Parigi. Avevo iniziato a progettare tavoli per alcune mostre, già cimentandomi nella ricerca "dell'essenza" di questo prodotto. Mentre disegnavo Less, mi veniva sempre in mente l'archetipo del tavolo. La sua forma esile e sottile doveva apparire miracolosa e desideravo che chiunque si domandasse: *Com'è fatto? Come sta in piedi?* Less, nell'analisi, si leggeva come un piano virtuale con quattro gambe e un profilo aerodinamico. La forma prismatica ottenuta era totalmente legata a questa volontà e a questa precisa ricerca estetica. Vent'anni dopo, LessLess rilancia la sfida. Ancora più sottile, più leggero, più misterioso. Ho sempre pensato che un oggetto di design dovesse evolversi nel tempo, reinventarsi con il progredire delle tecniche di produzione insieme alla complicità dell'industria che ne concretizza lo sviluppo. In questo senso, Less esiste grazie all'incontro con Unifor. Una lunga storia ci lega a Less ormai da vent'anni; una ricerca comune, ostinata, fiduciosa nel poter migliorare il design, curare ogni dettaglio, arricchire e sviluppare la gamma per raggiungere l'essenziale. Nello stesso modo il Totem, l'armadio girevole, si è progressivamente radicalizzato fino a raggiungere la scomparsa visiva della base: è finalmente diventato il monolito che ossessiona ogni mio progetto. Vent'anni separano Less da LessLess. Nell'album di famiglia, due generazioni si susseguono, testimoniando, l'una e l'altra, con autenticità, l'estetica e i valori culturali che le legano al loro rispettivo anno di nascita.

Jean Nouvel

I created Less in 1994 for the opening of the Fondazione Cartier in Paris. I had been designing tables for exhibitions and was already making investigations into “the essence” of this particular object. While I was working on Less, I kept thinking about the archetype of the table. I wanted to make a table so slender, so thin, that it would look miraculous. I wanted people to ask: *What is it made of? How does it stand up?* Less reads essentially as a virtual plane with four legs and aerodynamic contours. Its prismatic forms were the result of a very precise aesthetic investigation, driven by this desire to amaze. Twenty years later, Less Less presented the same challenge. It is even thinner and lighter, even more mysterious. I have always felt that a design object should evolve over time, reinventing itself by keeping abreast with technical developments in close collaboration with the manufacturer, who transforms it into reality. In this sense, Less owes its existence to Unifor. Our history around Less goes back twenty years by now. We have shared a stubborn and relentless quest to improve the design in every detail, enriching and developing the range while stripping it down to the essential. In the same way, we have minimized the forms of Totem, the rotating tower cabinet, until even the base disappeared from view and it finally became the monolith that is the obsession of all of my projects. Less and Less Less are twenty years apart. They are two generations in a family album, each a valid representative of the aesthetics and cultural values of their respective moments of birth.

Jean Nouvel



La serie LessLess è composta da un sistema modulare di tavoli, tavoli scrivania, postazioni con supporto tecnologico, cassettiere e contenitori per archiviazione destinati a spazi operativi, uffici direzionali, sale riunioni e di rappresentanza, che si caratterizzano per leggerezza formale, elevate prestazioni tecniche e grande qualità ambientale. Realizzati con materiali resistenti, che danno consistenza a volumi essenziali e forme ridotte a puro segno, questi arredi definiscono con rigorosa semplicità un ambiente di lavoro sobrio, razionale e autorevole, ma privo di retorica. Uno spazio funzionale dove la tecnologia non è invasiva.

The LessLess series consists of a modular system of tables, desk tables, and workstations with support for data technologies, drawer pedestals and filing cabinets for use in task areas, executive offices, conference rooms and boardrooms. They stand out for their lightness of form, high technical performance and environmental qualities. Built with durable materials that give substance to the essential volumes and pure geometric forms, these pieces define, with rigorous simplicity, a work environment that is restrained, rational and authoritative, yet devoid of rhetoric, for highly functional spaces where technology is never intrusive.



I caratteri identificativi dell'architettura di Jean Nouvel si manifestano compiutamente nei mobili della serie LessLess, evidenziando con chiarezza gli elementi stilistici che contraddistinguono il suo lavoro. La leggerezza formale, il rigore compositivo, la ricerca sui materiali, lo studio dei colori, l'uso di una tecnologia sempre presente e mai esibita sono riproposti nel disegno essenziale di questi elementi di arredo. Tavoli, postazioni operative e contenitori si concretizzano in solide strutture metalliche, definite da volumi primari, linee pulite, superfici lisce e profili contenuti. Un sistema modulare pensato per abitare i luoghi contemporanei del lavoro.

The identifying characteristics of the architecture of Jean Nouvel are fully manifested in the LessLess furniture series, the pieces of which clearly reveal the stylistic elements that distinguish his work. Lightness of form, compositional rigor, carefully selected materials, color studies, and an extremely discreet yet highly functional approach to IT technology are recurrent features of these minimalist furnishing elements. Tables, workstations and containers take form in solid metal structures, consisting of simple volumes, clean lines, smooth surfaces and compact contours. A modular system designed to inhabit contemporary work environments.



Il tavolo si configura come una struttura monolitica integralmente realizzata in alluminio; le gambe sono costituite da elementi estrusi con profilo a L, mentre il piano di lavoro è interamente eseguito in lamiera piegata, ottenuta attraverso accurate lavorazioni industriali. Gambe e piano sono assemblati mediante un particolare sistema di fissaggio che assicura elevate prestazioni tecniche e di sicurezza. Disponibile sia rettangolare che quadrato, in diverse dimensioni, il tavolo può essere utilizzato come scrivania, in versione direzionale e operativa, oppure come tavolo per riunioni.

The table takes the form of a monolithic structure made entirely of aluminum. The legs consist of extruded L-shaped profiles while the worktop is built from folded sheet-aluminum, manufactured using precision industrial processes. The legs and top are assembled together by means of a special fastening system that ensures safety and high technical performance. Made in both rectangular and square forms and in various sizes, the table can be used as a desk, in both executive and task-area versions, or as a conference table.







Qualificati da un disegno essenziale e accurati particolari costruttivi, la cassetiera su ruote e i mobili per archiviazione definiscono degli elementi funzionali che vanno ben oltre il semplice concetto di complementi di servizio. Questi contenitori modulari dalla forma compatta e le superfici lisce sono costituiti da basamento a scomparsa, schiena e fianchi rifiniti con un unico pannello di chiusura, ante dotate di dispositivo di apertura a pressione, piano superiore a spessore ridotto e attrezzatura interna a ripiani. Gli armadi sono realizzati in tre altezze, nella versione a terra (alto, medio e basso) e sospesa a parete (basso). La cassetiera e il contenitore basso possono trasformarsi in elementi di seduta con la semplice aggiunta di un cuscino in tessuto tecnico di colore nero. Tutti i componenti sono realizzati in alluminio con ricercate finiture in anodizzato naturale e verniciato nero soft.

With their minimalist design and precise structural detailing, the drawer pedestal on wheels and the storage cabinets are functional elements that go far beyond the simple concept of accessory pieces. These modular containers, compact in form and with ultra-smooth surfaces, consist of a concealed base, back and sides enclosed in a single, continuous surface, doors with push-to-open devices, interior shelving, and an extra thin top. The cabinets are available in three heights (tall, medium and low) in the freestanding version, and in a wall-hung version (low). With the addition of cushions in black high-tech fabric, the drawer pedestals and low cabinets can also be used as seating. All components are in aluminum with refined surface finishes, in natural-finish anodizing or painted in soft black matte.





Concepito come un vero e proprio monolito di grande rigore formale, il Totem è un innovativo contenitore girevole su base fissa a doppia apertura, che si presenta come un parallelepipedo assolutamente liscio e compatto, grazie all'eliminazione visiva del basamento, celato dietro le ante. Dotato di un esclusivo meccanismo nascosto di movimentazione delle ante (con rotazione e traslazione laterale), l'armadio è accessibile su due lati in modo da sfruttare al meglio la doppia profondità del mobile attrezzato per l'archiviazione.

Conceived as a formally rigorous monolith, Totem is an innovative revolving double-sided cabinet on a fixed base. The base is concealed behind the doors, so that the cabinet presents itself as a smooth and compact rectangular solid. It is accessible on two sides to make good use of its depth for document storage. The doors are equipped with a unique hidden opening mechanism (rotation plus lateral shift).



Da sempre impegnato nello sviluppo di soluzioni progettuali confortevoli, efficienti e rispettose dell'uomo e dell'ambiente, Jean Nouvel reinterpreta gli elementi di arredo della serie LessLess attraverso lo studio di nuovi componenti e particolari costruttivi, che propongono una concezione evoluta dello spazio-ufficio contemporaneo, decisamente orientata al benessere della persona. Pur mantenendo inalterate l'essenzialità del disegno e la leggerezza formale che caratterizzano la serie, i nuovi arredi evidenziano i tratti distintivi di un inedito percorso di ricerca progettuale e produttiva, dove si accentua maggiormente l'attenzione per i dettagli, le finiture e le funzionalità.

Always committed to the development of comfortable and efficient design solutions that respect both the user and the environment, Jean Nouvel has reinterpreted the furnishing elements of the LessLess series through new components and structural detailing and the elaboration of an advanced conceptual vision of the contemporary office that is firmly focused on well-being. Though they maintain the simplicity of design and lightness of form that characterize the series, the new furnishings display signs of a new direction in design and production, with an emphasis on greater attention to detail, finishes and functional features.



L'innovativa configurazione con sviluppo a L della postazione di lavoro, oltre a qualificarsi sul piano del design per l'estrema leggerezza formale, si caratterizza a livello costruttivo per le particolari soluzioni tecniche che assicurano elevate prestazioni funzionali e di sicurezza. Collegato al tavolo scrivania mediante speciali elementi di connessione sottopiano, il piano ausiliario di supporto tecnologico è sorretto da un unico pannello strutturale verticale, predisposto per il fissaggio e la regolazione del monitor e per il passaggio e la raccolta dei cavi di alimentazione degli impianti di rete.

The innovative L-shaped configuration of the workstation stands out not only in terms of visual design for its extreme lightness of form, but also in terms of structure for its special technical solutions that ensure a high degree of safety and technical performance. The auxiliary table for IT equipment is attached to the executive desk by special connecting elements beneath the worktop. It is supported by a single vertical structural panel which is specially designed for adjustable monitor accommodation and the passage of power and data cables.



Accuratamente progettati in ogni minimo dettaglio e prodotti mediante avanzate tecnologie e sapienti lavorazioni industriali, i tavoli, le postazioni e i contenitori LessLess sono interamente realizzati con strutture e componenti in alluminio e sono qualificati da soluzioni funzionali esclusive, che consentono di personalizzare ogni ambiente su specifiche esigenze di progetto. La nuova finitura nero soft, morbida al tatto, conferisce a questi pezzi di industrial design un ulteriore tocco di raffinata eleganza, ampliandone le possibilità compositive.

Carefully designed to the smallest detail and manufactured using advanced technologies and skilled industrial processes, the LessLess tables, workstations and containers are made of aluminum structures and components. Exclusive functional solutions permit personalization of every work environment to specific project requirements. The new finish in soft black, extremely smooth to the touch, gives these objects of fine industrial design an extra touch of elegance while increasing their compositional possibilities.





Lo spazio di lavoro è definito da una serie di arredi essenziali nel design e affidabili nelle prestazioni tecniche e di sicurezza. Accanto al tavolo scrivania, con gambe in profilati a L e piano di lavoro in lamiera piegata, sono posizionate le cassettiere su ruote e il mobile per archiviazione ad ante, proposto nella versione panca completata dal comodo cuscino di seduta in tessuto tecnico. Tutti i componenti sono realizzati in alluminio verniciato nella raffinata e funzionale finitura nero soft anti-impronta. Il piano di lavoro è disponibile anche nella esclusiva versione con inserto in Forbo nero integrato nella superficie.

The workspace is defined by a series of furnishings that are minimalist in design while delivering high technical performance and safety. The drawer pedestals on wheels and the filing cabinet with doors are positioned adjacent to the desk-table with legs in L-shaped profiles and worktop in folded sheet-metal. With the addition of a cushion in high-tech fabric, the cabinet doubles as comfortable seating. All components in aluminum, in the refined and functional soft black fingerprint-resistant paint finish. The worktop is also available in an exclusive version with black Forbo inserts integrated into the surface.









C L L 1 4 0 7 0

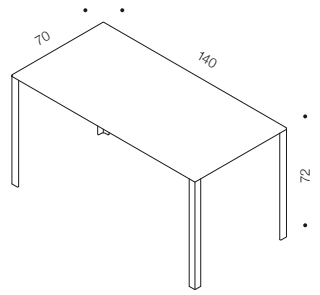

Tavoli scrivania
Desk tables

C L L 2 1 0 7 0

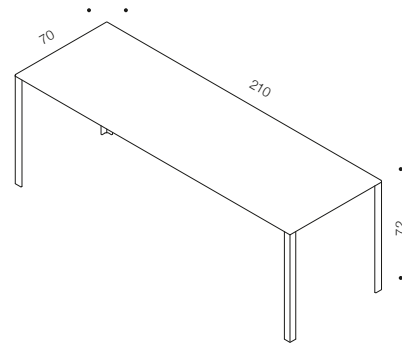

C L L 2 8 0 7 0

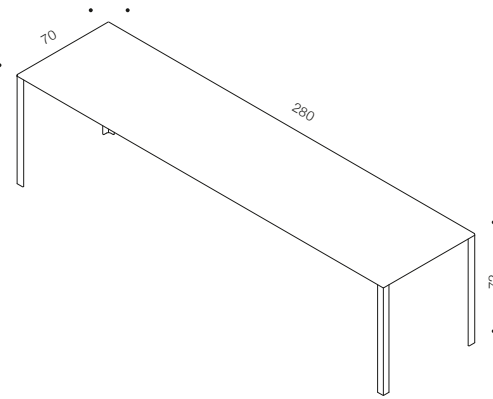

C L L P A N R C

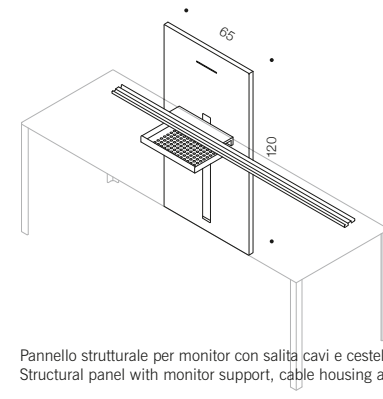

Pannello strutturale per monitor con salita cavi e cestello.
Structural panel with monitor support, cable housing and cable basket.

C L L 1 4 0 7 0 L V

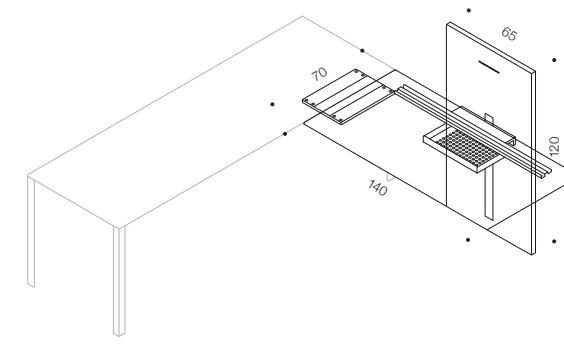

Allungo e pannello strutturale per monitor con salita cavi e cestello.
Extension and structural panel with monitor support, cable housing and basket.

C L L 1 6 0 8 0

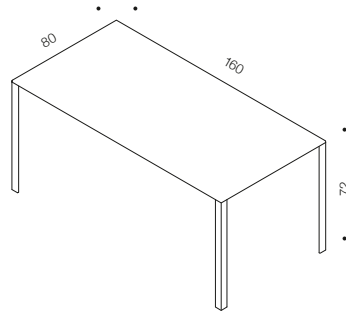

Tavoli scrivania
Desk tables

C L L 1 9 0 9 0

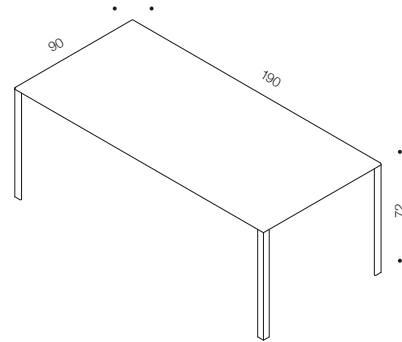

C L L 2 3 0 1 1 0

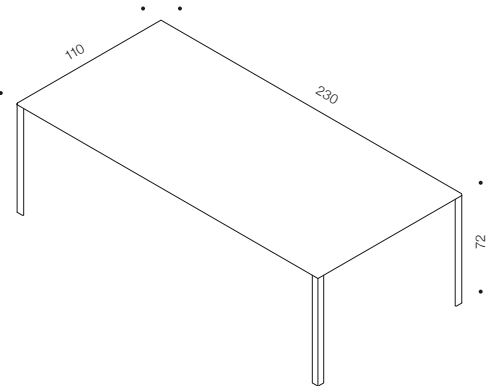

I A F S R 2 Z 0 1

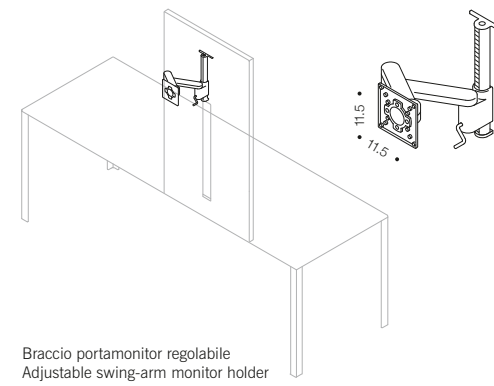

Braccio portamonitor regolabile
Adjustable swing-arm monitor holder

C L L A G G M 0

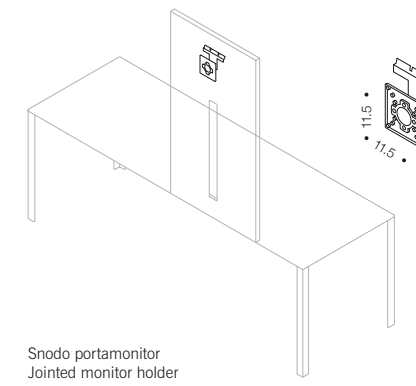

Snodo portamonitor
Jointed monitor holder

C L L C E S

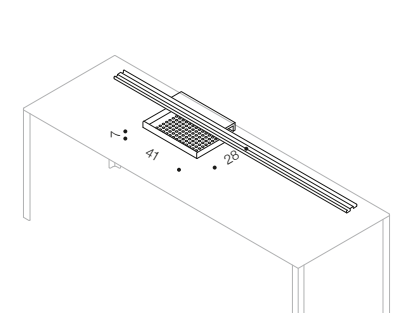

Cestello raccocatavi. Specificare il tipo di tavolo a cui va abbinato.
Wire basket for cables. Specify the type of table.

C L L 1 4 0 1 4 0

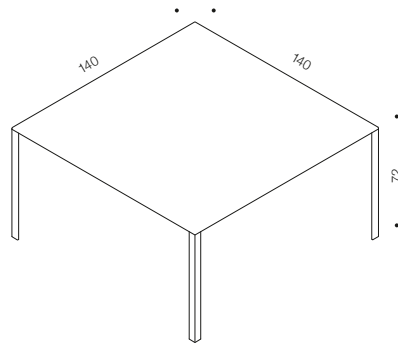

Tavoli
Tables

C L L 1 0 0 1 0 0 B

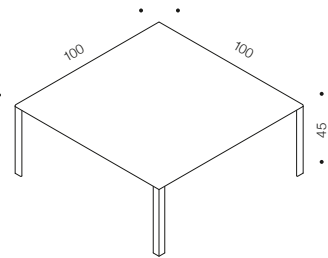

C L L 3 7 5 3 C 2

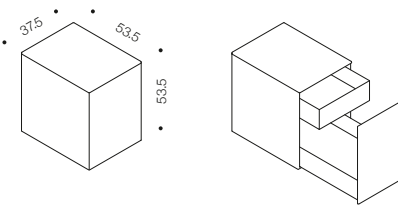

Cassettiere
Drawer pedestal

C L L 3 7 5 3 C 3

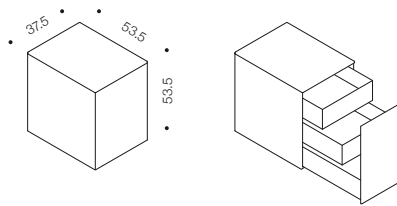

C L L C U S 3 7

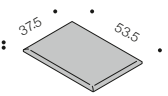

Cuscino per cassetiera
Cushion for drawer pedestal

C L L 1 8 0 3 7 P C

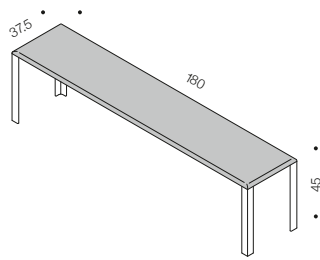

Panca con cuscino
Bench with cushion

C L L 1 8 0 3 7 P

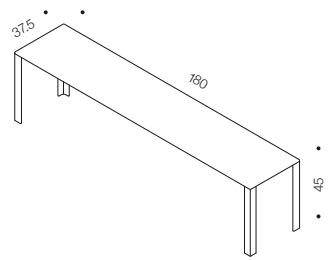

C L L 5 5 2 0 3

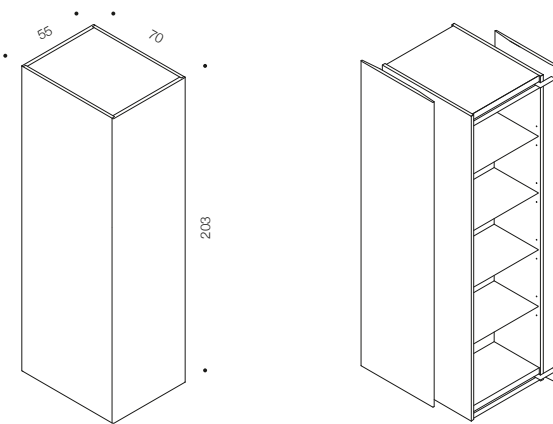

Totem girevole, bifacciale
Rotating tower cabinet, double-sided

C L L 1 6 0 8 0 F

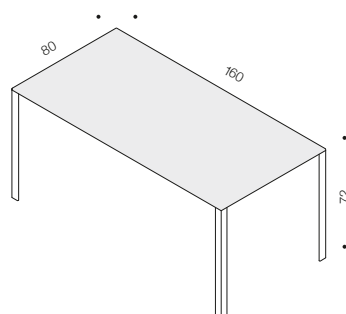

Tavoli meeting con piano in forbo nero
Meeting tables with black forbo top

C L L 1 6 0 9 0 F

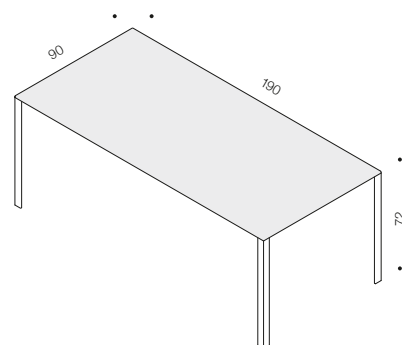

C L L 1 4 0 1 4 0 F

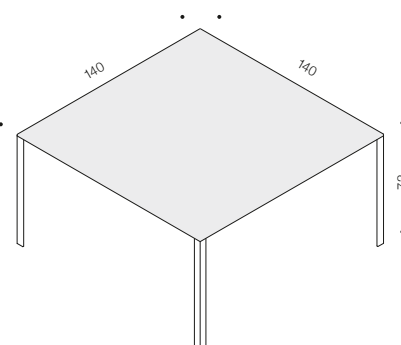

Finiture:
AD Anodizzato naturale
KS Nero soft

Finishes:
AD Natural-finish anodized
KS Soft black

C | L | L | L | 2 | 2 | 0 | 0 | 5 | 3 | M | A |

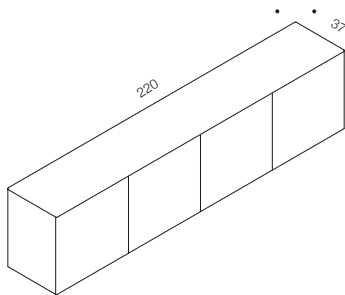

Armadio ad ante
Cabinet with doors

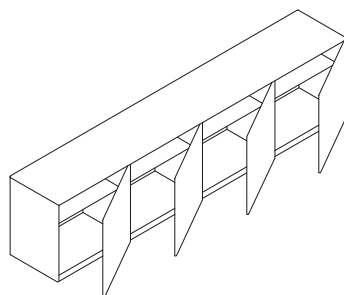

C | L | L | L | 2 | 2 | 0 | 0 | 5 | 3 | M | P |

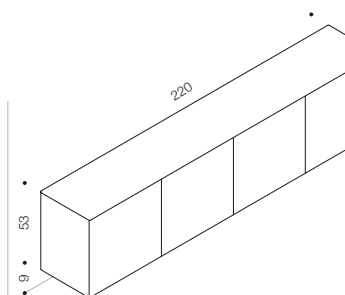

Armadio ad ante sospeso
Wall-hung cabinet with doors

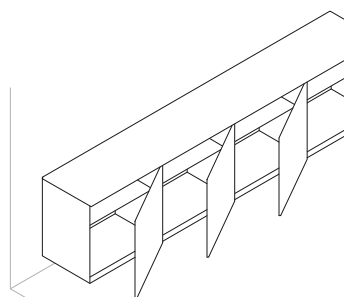

C | L | L | L | 2 | 2 | 0 | 0 | 9 | 1 | M | A |

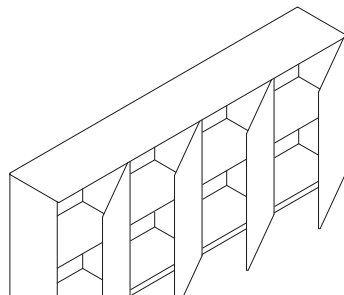
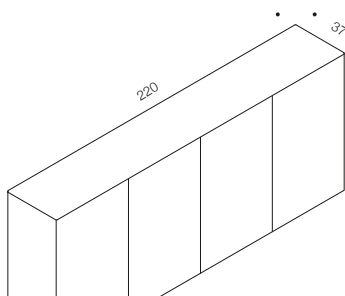

C | L | L | L | 2 | 2 | 0 | 1 | 2 | 8 | M | A |

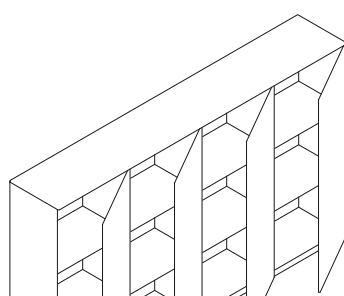
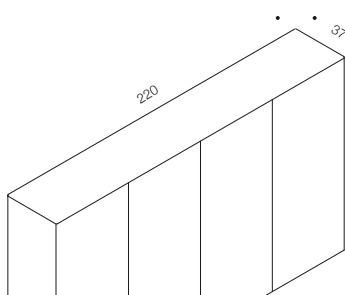

Finiture:
AD Anodizzato naturale
KS Nero soft

Finishes:
AD Natural-finish anodized
KS Soft black

C | L | L | C | U | S | 2 | 2 | 0 |

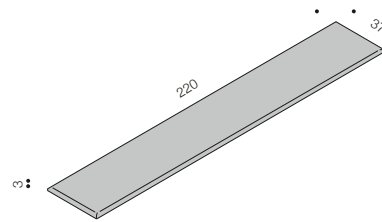

Cuscino per armadio
Cushion for cabinet

UniFor

Stabilimento e uffici

22078 Turate (Como)
via Isonzo 1
t 02 967 191
f 02 967 50859
f 02 967 50399
www.unifor.it
unifor@unifor.it

Filiali italiane

20121 Milano
corso Matteotti 14
t 02 7600 9024
f 02 7600 4765
uniformilano@unifor.it

Rivenditori italiani

70121 Bari
piazza Eroi del Mare 6
t 080 524 9373
f 080 524 9484
stecchi.system@tin.it

40128 Bologna
via del Lavoro 60
t 051 631 1368
f 051 631 1370
info@progetto-ufficio.com

39100 Bolzano
via Esperanto 3
t 0471 050 505
f 0471 050 500
info@arteobject.it

42040 Campegine (Reggio Emilia)
via Aldo Moro 8
t 0522 906 154
f 0522 906 697
prouf@tin.it

36030 Costabissara (Vicenza)
via Pasubio 17
t 0444 557 894
f 0444 557 073
fontanacontract@fontanasrl.net

16121 Genova
via Dante 2/6
t 010 553 1145
info@officedesign.it

80121 Napoli
via Carlo Poerio 34
t 081 245 2439
f 081 245 2439
fontanelnicola@virgilio.it

35020 Padova Z.I.
Loc. Saonara
via Irpina 56
t 049 879 1870
f 049 879 1871
info@ambienteufficio.it

90146 Palermo
via San Lorenzo, 155/161
t 091 689 0738
f 091 751 0656
mail@massimilianotroja.com

06100 Perugia
via Mario Angeloni 65
t 075 500 2715
f 075 500 8984
perugia@loretiarredamenti.it

51100 Pistoia
via N. Machiavelli 25
t 0573 975 458
f 0573 975 488
info@logosfurniture.it

33047 Remanzacco (Udine)
Strada di Oselin 78
t 0432 649 232
f 0432 668 633
info@multitema.it

00136 Roma
via S.T. D'Aquino 15
t 06 3975 4233 / 3974 6943
f 06 3976 0028
evospace@evospace.it

61010 Tavullia (Pesaro)
via Selvagrossa 24/26
loc. Case bruciate
t 0721 201 366
f 0721 202 483
dellachiar@delachiar.it

38100 Trento
via Dosso Dossi 4
t 0461 828 900
f 0461 828 901
info@habitat-ufficio.it

24048 Treviolo (Bergamo)
piazza Monsignor Premarini 1/3
t 035 578 8210
f 035 694 177
info@area35.it

31100 Treviso
via Ponchielli 2
t 0422 262 223
f 0422 262 386
info@sagola.it

37138 Verona
viale del Commercio, 10
t 045 825 0033
sever@sever.it

Filiali estere

Australia
Unifor Australia Pty Ltd
140 Bank Street
Pyrmont, N.S.W. 2009
t (02) 9552 9552
f (02) 9552 9553
sydney@uniforaustr.com

Unifor Melbourne Office
450 Latrobe Street
Melbourne Victoria 3000
c/o Phoenix Lane
t (03) 9329 5900
f (03) 9329 9766
melbourne@uniforaustr.com

Unifor Brisbane
3/3 Florence St
Brisbane 4000
t (07) 3250 8700
f (07) 3250 8799
brisbane@uniforaustr.com

Dubai
Unifor s.p.a.
Jumeirah Business Centre 2
Unit 2104
Jumeirah Lakes Towers
JLT, Dubai U.A.E.
t (971) 4 454 2294
f (971) 4 454 2193
unifordubai@unifor.it

France
Unifor France S.A.
6 rue des Saints Pères
75007 Paris
14 rue Pierre Nicolau
93582 Saint Ouen (Cedex)
t (01) 4012 7717
f (01) 4010 0124
unifor@unifor.fr

Great Britain
Ergonom Ltd.
Whittington House
19-30 Alfred Place
London WC1E 7EA
t (0207) 3232 325
f (0207) 3232 032
enquiry@ergonom.com

Hong Kong
Unifor Hong Kong Ltd.
19th Floor
Top Glory Tower
262 Gloucester Road
Hong Kong
t (852) 2836 9333
f (852) 2836 9997
unifor@unifor.com.hk

Singapore
Unifor Singapore Pte Ltd
1 Kaki Bukit Road 1
#02-39 Enterprise One
Singapore 415934
t (65) 6221 1822
f (65) 6221 1833
general@unifor-asia.com

U.S.A.
Unifor
149 Fifth Avenue
New York, NY 10010
t (212) 673 3434
f (212) 673 7317
unifor@uniforusa.com

Rappresentanze estere

Austria
O'Hagan Office
Am Gestade
A-1010 Wien
t (01) 535 4075
f (01) 535 40759
office@pfau1010.com

Belgium
SV Interior Projects NV/SA
Koningin Astridlaan 59
Avenue Reine Astrid
B-1780 Wemmel
t (02) 531 1350
f (02) 531 1351
info@sv.be

Canada
Italinteriors Contract
445 King Street East
Toronto, Ontario M5A 1K9
t (416) 364 1011 ext 212
f (416) 364 7978
info@italinteriors.com

Chile
a0
Narciso Goycolea
3955 Vitacura
Santiago de Chile
t +56 2 2894 7082
info@a-cero.cl

Croazia
Art Avantgarde
ilica 15
Zagreb HR
t (1) 481 2900
f (1) 481 7217
aag.dizain.centar@zg.hinet.hr

Erceg Interijeri
Uprava I Salon Namjestaja
Selska cesta 14
10000 Zagreb
t (1) 370 2166
f (1) 370 2167
erceg-interijeri@zg.htnet.hr

Czech Republic
Konsepti
Komunardu 32
170 00 Praha 7
t (0222) 326 928
f (0222) 321 358
studio@konsepti.cz

Germany
München
mobile (0) 151 5045 0631
udenk@unifor.it

Lobitzweg 1
12557 Berlin
t (030) 6594 2150
f (0322) 2370 6727
mobile (0) 177 407 7229
i.kirste@unifor.de

Greece
Avepe S.A.
11-13, Sina Street
10680 Athens
t (30) 6957 507853
unifor@avepe.gr

Holland
SV Interieur Groep
Terbregse Rechter
Rottekade 137
3055 XC Rotterdam
t (010) 211 2050
f (010) 422 3495
info@sv.nl

Showroom
Dorpsstraat 75
1182 JC Amstelveen
t (020) 347 2130
f (020) 647 0095

Hungary
Variooffice
Mezsgye utca 20/B
H-1237 Budapest
t (20) 468 2505
f (20) 350 9394
zoltan.mihalszky@variooffice.hu

Ireland
O'Hagan Office
Time Place
21 Corrig Road
Sandyford
Dublin 18
t +353 87 979 6919
goh@ohagan.ie

Israel
Kfar Saba
44150 NorthernIndustrial Zone
P.O.B. 5086, Israel
t (09) 7403034
f (02) 531 1351
shira@innovate.co.il

Japan
Shukoh Co. Ltd.
Nihon Seimei Kawasaki Building
1-1, Minami-machi
Kawasaki-ku, Kawasaki-shi
210-0015 Kanagawa
t (044) 210 5123
f (044) 246 9861
sec@shukoh.co.jp

Showroom
Tokyo Design Center 7th floor
5-25-19, Higashi-Gotanda
Shinagawa-ku, Tokyo 141-0022
t (03) 5798 2231
f (03) 5498 2232

New Zealand
Cite Ltd.
18 Normandy Road
Mt Eden
Auckland 1001
t (09) 623 9233
f (09) 623 0233
katrina@citeltd.co.nz

Norway
Expo Nova Mobelgalleri AS
P.O. Box 554 Skoyen
N-0214 Oslo
t (0047) 2313 131340 / 48
f (0047) 2313 1341
andreas@expo-nova.no

Portugal
Helder Gonçalves
Largo do Cê 145
4595-298 Penamaior
t (255) 866 001
f (255) 866 002
helder@spring.mail.pt

Qatar
Office System
P.O.Box: 14715
Doha
t (974) 432 4034
f (974) 432 3746
adhami@office-system.net

Spain
Unifurniture, S.L.
c/. Aribau, 230 - 240 8º
08006 Barcelona
t (093) 412 4635
f (093) 412 4831
info@unifurniture.net

Switzerland
Unitrend
Lorzenparkstrasse 4
6330 Cham
t (041) 790 5454
f (041) 790 5575
info@unifor.ch

Turkey
Alter
Behlül sok. no. 23 pk 34674
Kuzguncuk Üsküdar
Istanbul
t (0216) 341 2323
f (0216) 341 6363
mail@exteramimarlik.com

Venezuela
Collectania
Cuadra Creativa y Gastronómica,
6º transversal de Los Palos Grandes,
entre 3ª y 4ª Av.
1060 Caracas
t + 58 212 2867518 / 2869235
f + 58 212 2850669
jmiodownik@collectania.com.ve

Art Direction e Graphic Design
Studio Cerri & Associati
con Giulio Schweizer

Foto: Mario Carrieri
Testi: Livio Salvadori

Fotolito: Pluscolor
Stampa: Grafiche Mariano
Finito di stampare: Gennaio 2014

Unifor ha ottenuto le certificazioni
UNI EN ISO 9001:2008
e UNI EN ISO 14001:2004.

I prodotti illustrati nel presente catalogo sono conformi all'allegato DLGS 81:2008 e rispondenti alle principali norme applicabili ai diversi tipi di prodotti. I prodotti descritti nel catalogo sono composti da materiali in classe E1 (a basso contenuto di formaldeide), e hanno ottenuto la certificazione Greenguard®.

Unifor has obtained UNI EN ISO 9001:2008 and UNI EN ISO 14001:2004 certification.

The products illustrated in this catalog are in conformance with the Italian decree law DLGS 81:2008 and with all of the principal regulations applicable to the various types of products. The products described in this catalog are made with class E1 materials (low formaldehyde content), and are Greenguard® certified.

